

Quick connector, 8/10 mm slot, 0°



- ▶ For the right-angled connecting of two profiles
- ▶ Very good accessibility for tools during assembly
- ▶ O-ring for fastening allows overhead assembly
- ▶ Quick connectors can be swiveled into the profile slot at the point of assembly
- ▶ Profile finishing:
blind hole DI, DB11, DB17 or through hole DI, D11, D17
- ▶ Note differing drilling intervals and load-bearing capacities when using with radial compensation ("Technical data" p. 19-6)

Optional accessories:

- ▶ Anti-torsion element (p. 3-41)
- ▶ Radial compensation (p. 2-85)
- ▶ Drilling jig (p. 14-2)
- ▶ Cover cap (p. 3-53)

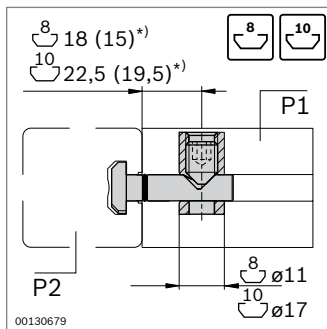

Slot	F_{max}	M_{max}
8 / 8	500 N	40 Nm
8 / 10	2000 N	70 Nm
10 / 10	4000 N	140 Nm

*) With the use of radial compensation

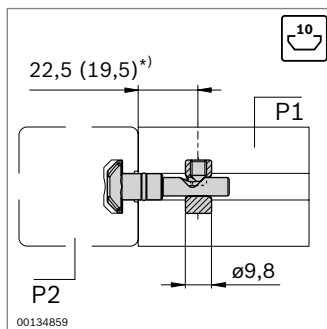

Slot	F_{max}	M_{max}
10 / 10	800 N	50 Nm

*) With the use of radial compensation

Quick connector, 0°	P1 / P2	D ESD	No.
	(mm)		
steel; galvanized	8 / 8	11	3 842 535 459
	8 / 10	11	3 842 535 464
	10 / 10	17	3 842 535 458
steel, stainless	8 / 8	11	3 842 548 934
	8 / 10	11	3 842 548 935
	10 / 10	17	3 842 548 936

- ▶ Quick connector 9.8 with smaller connector sleeve
- ▶ The hole for the connector sleeve does not make contact with the slot flanks. This allows a visually attractive connection; the slot can be completely closed with the cover profile

Quick connector 0°, connector sleeve D = 9.8	P1 / P2	D ESD	No.
	(mm)		
steel; galvanized	10 / 10	9.8 ¹⁾	3 842 541 412

¹⁾ No standard hole in modular dimensions 40, 50 and 60
Target distance from profile end: 22.5mm